

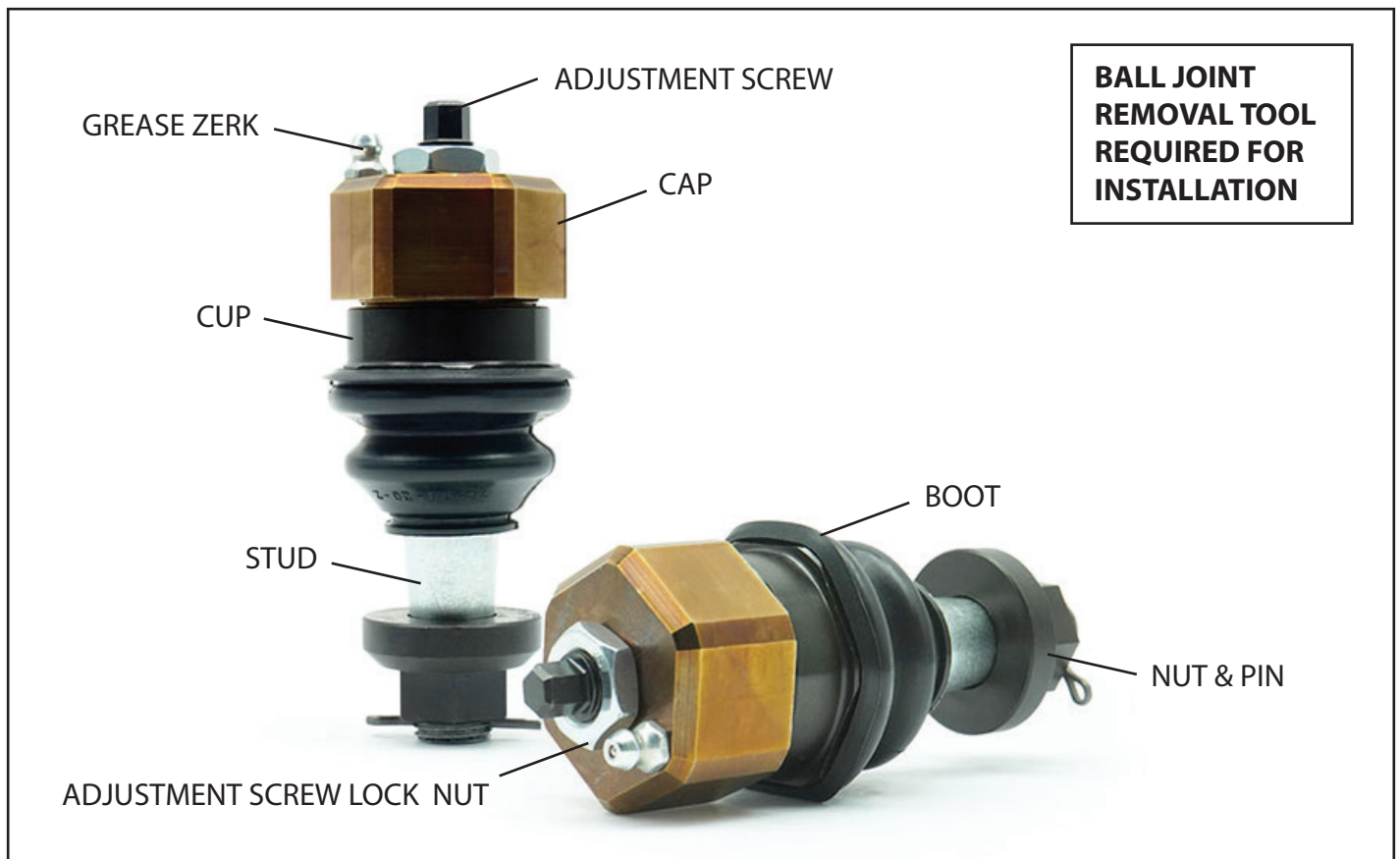

# SANDCRAFT MOTORSPORTS LOWER BALL JOINT PRO R INSTALLATION INSTRUCTIONS

**THANK YOU FOR PURCHASING A LOWER BALL JOINT KIT FROM SANDCRAFT!**  
Please read the instructions completely before beginning installation.



1. Remove bottom Limit Strap hardware (if applicable)
2. Raise the vehicle, secure with jack stands.
3. Remove the front wheels.
4. Remove the sway link lower end hardware.  
**\*IMPORTANT:** Use a strap to secure the upper control arm to a vehicle tie down point. Unsecured suspension hanging weight **WILL** damage the inner Tie Rod End.
5. Remove Axle Nut.
6. Remove the Lower Ball Joint Nut.
7. Remove the 2 Brake Hose Bolts from the knuckle.
8. Remove the Outer Tie Rod End from the Knuckle.
9. Remove Brake Caliper Hanger Bolts (X2).  
**NOTE:** Zip Tie the Brake Caliper Assembly to the Rotor at this point to keep the Brake Components assembled.
10. Carefully shock the Lower Ball Joint Knuckle to break it free.



# SANDCRAFT MOTORSPORTS LOWER BALL JOINT PRO R INSTALLATION INSTRUCTIONS

11. Remove the Upper Ball Joint Pinch Bolt. Pull the Knuckle down and away from the vehicle to remove.
12. Remove Lower Shock Mounting Bolt. \*For on car service skip to setp #15.
13. Remove Bumper Fascia to gain access to the Lower Control Arm Bolts.
14. Remove Lower Control Arm Bolts and remove Lower Control Arm from vehicle.
15. Remove Lower Ball Joint Snap Ring. Press out the OE Ball Joint from the Lower Control Arm using the correct Press Drivers.
16. Thoroughly wipe clean the Lower Control Arm Lower Ball Joint Pocket.
17. Install the Lower Control Arm into the vehicle, Install the Lower Control Arm Bolts (X2). Do not tighten these bolts yet.
18. Install the Lower Shock Mount Bolt (Do not tighten these bolts yet).
19. Unbox your Lower Ball Joints.
20. Remove the Stud Nut.
21. Remove the Dust Boot.
22. Remove the SANDCRAFT Cap from the Cup.
23. Apply a liberal amount of Threadlocker to the outer ring of the Cup and insert the Cup into the Lower Control Arm Pocket from the bottom. NOTE – This part is not designed with a press fit. It is common for it to slide right in, sometimes it needs some coaxing - both are normal due to variable tolerances in the OE components.
24. Apply grease to the stud ball head. Apply threadlocker to the Cap threads and insert the Cup/Stud into the top of the Lower Ball Joint Pocket. Thread together with the Cup. Torque to 200 ft. lbs. You can grease the ball joint at this time.
25. Install Dust Boot Cover and secure dust boot edge over the lip on the Lower Ball Joint Cup. Once secured, install the safety wire into the recessed groove on the Dust Cover by wrapping it around once, then twist to tighten and trim the extra off.
26. At this time tighten the adjustment screw until you feel pressure on the ball joint but it still has a full range of motion then back off 1/4 turn. Now tighten the adjustment screw lock nut.
27. Install the Knuckle. Collect the Lower Ball Joint Stud, then the Axle Stud and finally the Upper Ball Joint Stud.
28. Loosely install the Upper Ball Joint Pinch Nut & Bolt. Do not tighten.
29. Install the Brake Rotor/Caliper Assembly. Install Caliper Hanger Bolts (X2). Use threadlocker, torque to 73 ft. lbs.
30. Install the Outer Tie Rod End.
31. Install Axle Nut, do not tighten.
32. Torque Lower Control Arm Bolts (X2). Torque to 133 ft. lbs.
33. Install the Lower Shock Bolt. Torque to 133 ft. lbs. NOTE: If you have Limit Straps, DO NOT re install them at this time, wait until the car is back on the ground.



# SANDCRAFT MOTORSPORTS LOWER BALL JOINT PRO R INSTALLATION INSTRUCTIONS

34. Install Sway Link End, torque to 89 ft. lbs.
35. Torque Axle Nut to 89 ft. lbs.
36. Torque Outer Tie Rod End to 52 ft. lbs. + 90 degrees.
37. Install Brake Line Bracket bolts to the knuckle, torque to 3 ft lbs.
38. Torque the Lower Ball Joint Nut to 100 ft. lbs. Use Red Threadlocker.
39. Install the Stud Nut Cotter Pin.
40. Torque the Upper Ball Joint Pinch Bolt to 52 ft. lbs.
41. Install the Bumper Fascia.
42. Install the Wheel. Torque to Manufacturer specifications.
43. Lower the vehicle to the ground.
44. If you have Limit Straps, re install them at this point.

**PLEASE CONTACT US AT (480)-539-4438 OR SANDCRAFT@SANDCRAFT-MOTORSPORTS.COM IF YOU HAVE ANY QUESTIONS.**