

INSTALLATION INSTRUCTIONS

SANDCRAFT A-ARM BUSHING & SLEEVE KIT - 2018+ TURBO 'S' / PRO XP



TOOLS REQUIRED:

- Grease
- Floor jack & jack stands
- Rubber mallet
- Drill
- Torque wrench
- 15mm wrench (2)
- Lock ring pliers
- Lug wrench

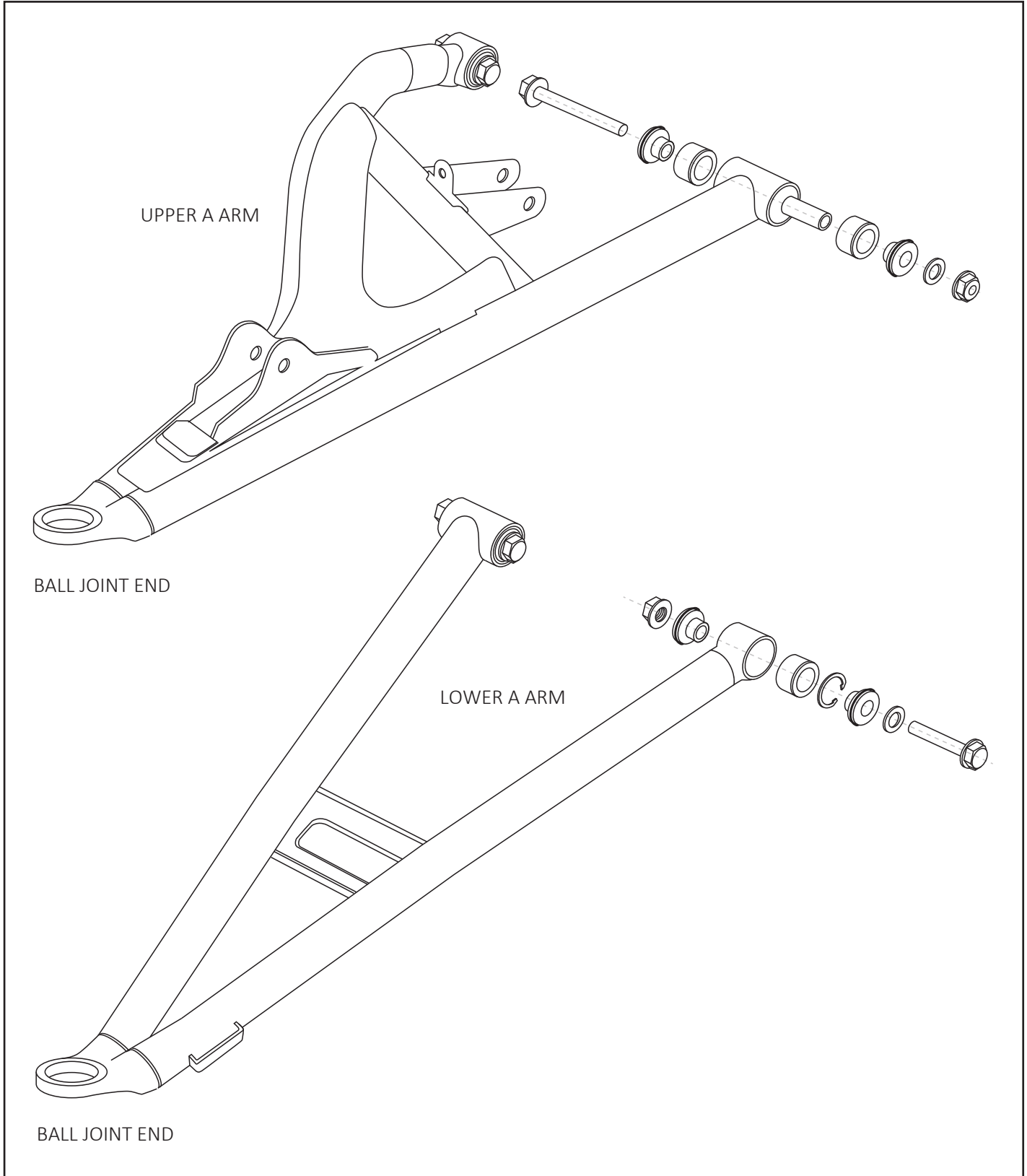

INSTALLATION INSTRUCTIONS

SANDCRAFT A-ARM BUSHING & SLEEVE KIT - 2018+ TURBO 'S' / PRO XP

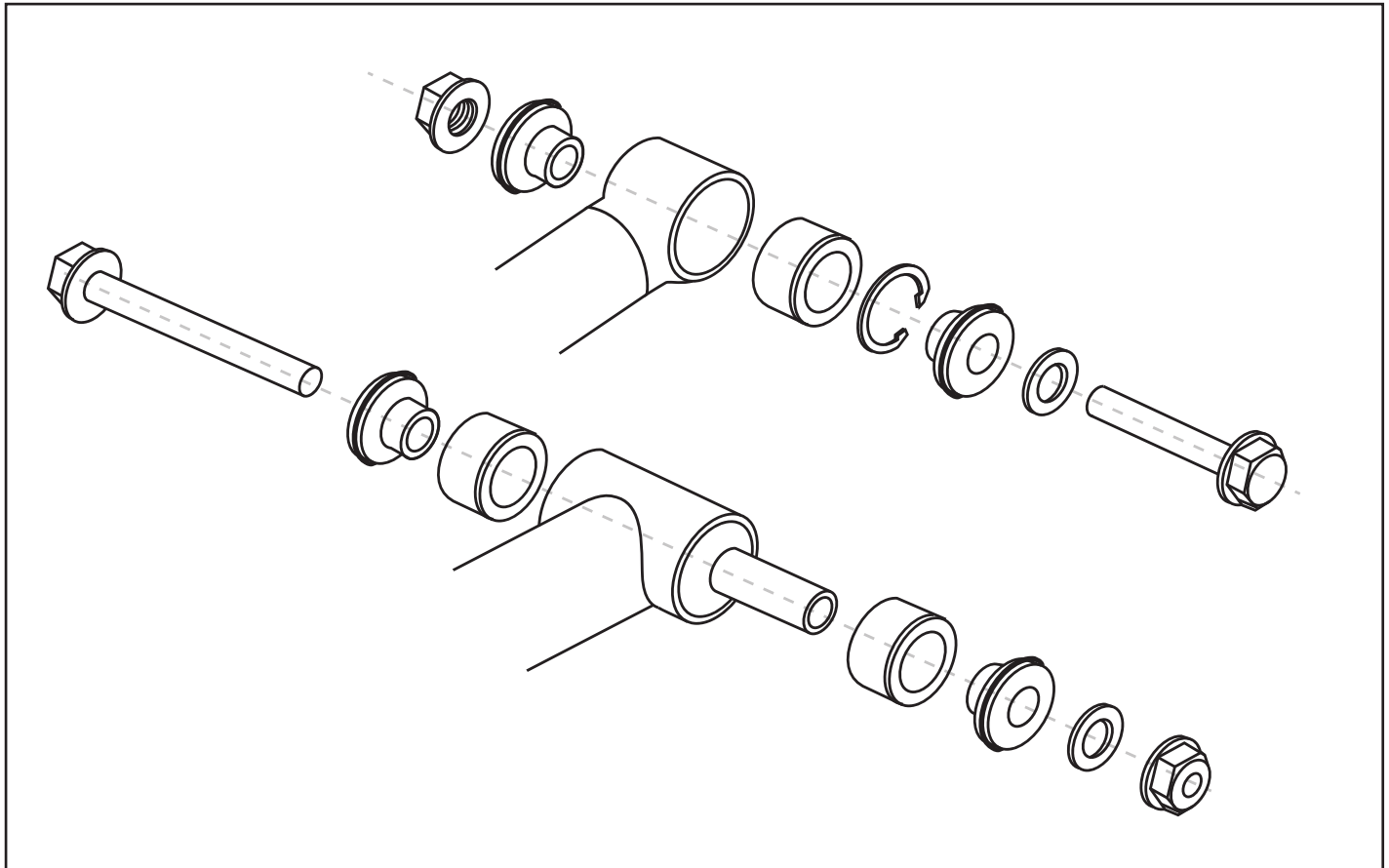

1. Remove the four (4) T40 bolts that hold the lower half of the front bumper on.
2. Break loose the wheel lug nuts on the wheels, then safely jack the front end up, secure it and remove the wheels.
3. Remove the 15mm lower shock bolt from the upper A Arm.
4. Remove the brake line bracket.
5. Remove the 15mm upper ball joint pinch bolt and Separate the upper A Arm from the ball joint.
6. Remove (2) upper 15mm bolts from the Upper A Arm frame mounts. Turning the wheels all the way in one direction or the other can help expose these mounts. Remove the upper A Arm from the vehicle.
7. Remove the old collar and bushings from the A Arm and clean all surfaces.
8. Grease your new SANDCRAFT Delrin bushings and insert them into the Upper A Arm.
9. Grease and install the SANDCRAFT Collars. Repeat this process for both sides of the Upper A Arm.
10. Re install the Upper A Arm into the frame mounts using new bolts, nuts, washers and lock ring where applicable. (torque to 44 ft lbs). These hardware components are not included with this kit.
11. Re install the 15mm upper ball joint pinch bolt. (torque to 44 ft lbs)
12. Re attach the brake line bracket.
13. Re attach the lower shock mount to the Upper A Arm (torque to 40 ft lbs)
14. Remove the 15mm lower ball joint pinch bolt and separate the Lower A Arm from the ball joint.
15. Remove the (2) 15mm bolts from the lower A Arm frame mounts and remove it from the vehicle.
16. Grease your new SANDCRAFT Delrin bushings and insert them into the Lower A Arm.
17. Grease and install the SANDCRAFT Collars. Repeat this process for both sides of the Lower A Arm.
18. Re install the Lower A Arm into the vehicle using new bolts, nuts, washers and lock ring where applicable. (torque to 44 ft lbs) These hardware components are not included with this kit.
19. Re install the 15mm lower ball joint pinch bolt (torque to 44 ft lbs)
20. Re install the wheels and torque to manufacturer spec. Lower the vehicle to the ground.
21. Double check all your hardware is installed and torqued correctly.